



DS-2CC102/112/192N-IR3 Color IR Camera

- Compact design
- 1/3" Sony CCD
- Minimum Illumination: 0.1Lux/F1.2 (0 Lux with IR)
- Auto white balance, auto gain control, electronic shutter control and backlight compensation
- Internal synchronization
- Weather Proof: IP66 standard



Unit: mm

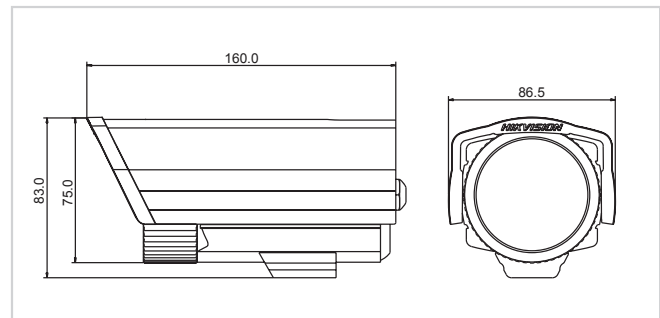

Specifications

	DS-2CC102N-IR3	DS-2CC112N-IR3	DS-2CC192N-IR3	
Camera	Image Sensor	1/3 inch SONY Super HAD CCD		
	Effective Pixels	NTSC: 510 (H) × 492 (V)	NTSC: 768 (H) × 494 (V)	NTSC: 768 (H) × 494 (V)
	Horizontal Resolution	420TVL	480TVL	540TVL
	Signal System	NTSC		
	Min. Illumination	0.1Lux @ F1.2 (0 LUX with IR)		
	Electronic Shutter Speed	1/50 (1/60)s to 1/100,000s		
	Synchronization	Internal Synchronization		
	Video Output	1Vp-p Composite Output (75Ω / BNC)		
	S/N Ratio	More than 48 dB		
Lens	BLC	ON		
	Lens	12mm (3.6mm, 6mm, 8mm, 16mm option)		
General	IR Distance	Approx 30 to 40 meters		
	Water and Dust Resistance	IP66		
	Power Supply	12VDC, ±10%		
	Power Consumption	6W MAX		
	Working Temperature	-10°C ~ 60°C		
	Dimensions(mm)	86.5 × 83 × 160 (3.43" × 3.29" × 6.34")		
	Weight	1000g (2.2lbs)		